

SPECIFICATION

1. SCOPE

This specification is applied to the piezo-element.

2. SPECIFICATION

(at 25°C)

2.1 Resonant Frequency	:	4.0 ± 0.5 KHz
2.2 Resonant Resistace	:	500 Ω max
2.3 Capacitance	:	34000 pF ± 30% at 100Hz
2.4 Input Voltage	:	30 Vp-p max
2.5 Operating Temperature	:	-20~+50°C
2.6 Storage Temperature	:	-20~+60°C
3. DIMENSION	:	as per figure

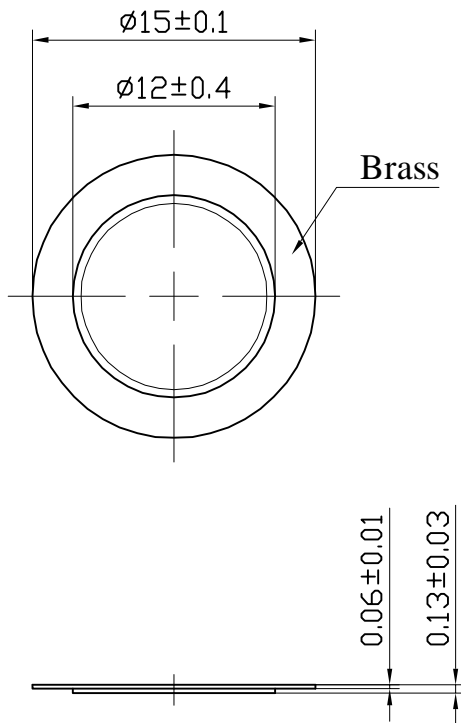

TOLERANCES UNLESS NOTED OTHERWISE .X ± .XX ± .XXX ± 90° FORMED +2° ANGLES -1° FIRST ANGLE PROJECTION 	DRAWN		KEPO MODEL NO.	CUSTOMER			
	DESIGN		MFT-15T-4.0A1	CUSTOMER NO.			
	CHECKED						
	APPROVED		DWG NO.	VER	1.2	SCALE	
	DATE	05.03.21	KP3.843.814	UNIT	mm	SHEET	
	CONTRACT NO.			KEPO CO.,LTD.			
AGENCY APPROVAL			TEL:(+86)574-88370330 FAX:(+86)574-88370329				